



Operation and Installation Manual

Pulsar® Precision System

Model PS-1HCE



Table of Contents

1	Safety Precautions	4
1.1	Safety Conventions	4
1.2	Safety Statements for the Pulsar® PS	4
2	Introduction	6
2.1	Overview of Operation	6
2.2	Process Flow Diagram	6
3	Pulsar® Precision Feeder Overview	7
3.1	Components List	7
4	Pre-installation Instructions	8
4.1	Prepare the Site	8
4.1.1	Site Requirements	8
4.2	Gather Equipment for Feeder Installation	8
4.2.1	Pulsar® Precision Components	8
4.2.2	Essential Equipment Supplied by Others	9
4.2.3	COTS Tools	9
4.2.4	PPE	9
4.3	Pre-Installation Checklist	9
5	Installation Instructions	10
5.1	Install the Booster Pump- Venturi Loop	10
5.2	Install the Flow Switch	10
5.3	Feeder Setup- Connect the Discharge Tubing Line	11
5.4	Feeder Setup- Connect the Inlet Tubing Line	11
5.5	Mount the Control Box	11
5.6	Wire the Booster Pump to the Control Box	11
5.7	Connect the Flow Switch Cable	12
5.8	Prime the System	12
6	Post-Installation Instructions	13
6.1	System Startup	13
6.1.1	Feeder Preparation	13
6.1.2	Control Box Preparation	14
6.1.3	System Power Up	15
7	Operation Instructions	16
7.1	Fill the Hopper	16
7.2	Fill the Hopper (Dustless Procedure)	17
8	Preventative Maintenance	18
8.1	Preventative Maintenance Schedule	18
8.2	Cleaning Procedures	19
8.2.1	Equipment Needed	19
8.2.2	Clean the Grid Basket (Online Cleaning Instructions)	19
8.2.3	Comprehensive (Offline) Cleaning Instructions	20

9	Troubleshooting Guide	22
10	Appendix	23
10.1	Requirements and Specifications	23
10.1.1	Requirements for Product Installation and Operation	23
10.1.2	Product Specifications	23
10.1.3	Optional Feed Rate Capability	24
10.2	Electrical Schematics	25
10.3	Replacement Parts List and Views	28
11	Limited Warranty	31
	Service	31
	Exclusions	31

List of Figures

Figure 1.	Process Flow Diagram - Chlorination System	6
Figure 2.	Front View of Pulsar® Precision Feeder	7
Figure 3.	Complete the 1 ½" piping run	10
Figure 4.	Discharge Tubing Connection	11
Figure 5.	Wire the Booster Pump	11
Figure 6.	DIP Switch Location and Feed Cycle Settings	14
Figure 7.	Bucket Funnel Installation	17
Figure 8.	Bucket Funnel Removal	17
Figure 9.	115 VAC Control Box Wiring Schematic	25
Figure 10.	230 VAC Control Box Wiring Schematic	26
Figure 11.	Feeder Junction Box Wiring Schematic	27
Figure 12.	Hopper and Base Exterior Components View	28
Figure 13.	Hopper Interior Components View	29
Figure 14.	Base Interior Components View	30

List of Tables

Table 1.	Pre-Installation Checklist	9
Table 2.	Post-Installation Checklist	13
Table 3.	Monthly Maintenance	18
Table 4.	Semiannual Maintenance	19
Table 5.	Site Requirement	23
Table 6.	Accessory Requirements	23
Table 7.	Operational Specifications	23
Table 8.	Chemical Feed Rate Specifications	23
Table 9.	Feed Solenoid On/Off Time vs Available Chlorine Delivery Rate (lbs/day) ..	24

1 Safety Precautions

Danger, Warning, Caution, and Note statements are used throughout this manual to emphasize important safety information. The statements are defined below.

1.1 Safety Conventions

 **Danger:** Indicates a hazardous situation which, if not avoided, will result in death or severe injury.

 **Warning:** Indicates a potentially hazardous situation which, if not avoided, can result in personal injury.

 **Caution:** Indicates a potentially hazardous situation which, if not avoided, can result in minor personal injury or equipment damage.

Note: Information that may assist in completing a task correctly or for maintaining the machine in good operating condition.

1.2 Safety Statements for the Pulsar® PS

 **Warning:** For your protection, carefully and completely read the information provided in this manual before attempting to assemble, install, operate, or maintain this product. Retain these instructions for future reference. Failure to follow the instructions or information in this manual may result in injury and damage to the product and may affect warranty coverage.

 **Danger:** Calcium hypochlorite is hazardous. Please refer to the Safety Data Sheet for additional information and precautions regarding the proper handling of Pulsar® Plus Briquettes. If any part of this profile is unclear to you, please stop immediately and contact Sigura at (800) 478-5727.

 **Danger:** This system contains liquid under pressure and calcium hypochlorite solution can be discharged unexpectedly. Operate and service all components and attached piping that contain liquid cautiously until you are certain that the system has been depressurized and drained. Failure to do so may result in death or serious injury.

 **Danger:** Use suitable personal protective equipment (PPE) at all times to avoid physical contact with calcium hypochlorite solution or vapor. Failure to do so may result in death or serious injury. Please refer to the Safety Data Sheet for additional information and precautions regarding the proper handling of calcium hypochlorite.

 **Danger:** Do not allow Pulsar® Plus Briquettes to come into contact with any foreign matter or chemicals. Calcium hypochlorite is chemically reactive with many substances including, but not limited to water, water treatment products, pool treatment products, acids, organics, nitrogen-containing compounds, dry powder fire extinguishers (containing mono-ammonium phosphate), oxidizers, and corrosive, flammable, and combustible materials. Contamination or improper use of Pulsar® Plus Briquettes may cause a violent reaction that produces heat, an explosion, a fire, and the release of toxic gases, and result in death or serious injury. Please refer to the Safety Data Sheet for additional information and precautions regarding the proper handling of calcium hypochlorite.

Danger: All wiring connections, fusing, grounding, inspection, and maintenance of wiring must be performed by a licensed electrician in accordance with the National Electric Code (NEC), Occupational Safety and Health Act (OSHA) in the United States, and all local electrical codes. Failure to properly install and wire this product can result in property damage, serious injury, or death, and may affect warranty coverage.

Warning: Clean up, without delay, any leakage or spillage of Pulsar® Plus Briquettes or calcium hypochlorite solution. Please refer to the Safety Data Sheet for additional information and precautions regarding the proper disposal of calcium hypochlorite. Failure to do so may result in death or serious injury.

Warning: Always operate system with electrical component enclosures in place. Failure to do so may result in injury.

Warning: Always operate system components with safety guards in place. Failure to do so may result in injury.

Warning: Observe and follow all location-specific safety procedures. Failure to do so may result in injury.

Warning: **Always be careful when adding muriatic acid to water;** this combination creates an exothermic reaction, which gives off heat. Failure to take care may result in serious injury.

Caution: Use only replacement parts identified in 10.3 Replacement Parts List and Views on page 28. Do not paint over or remove unit nameplates, labels, or tags so that proper replacement parts may be identified.

The system is designed with specific motor characteristics. Changing motor types will change the operating characteristics of the system, which may cause injury and may void the warranty of this chlorinator.

Caution: Use of any briquettes or other chemicals other than the Pulsar® Plus Briquettes designed for use with this chlorinator will void this warranty.

2 Introduction

The patented Pulsar® Precision feeder creates a consistent solution of calcium hypochlorite used for water disinfection.

2.1 Overview of Operation

The Pulsar® Precision feeder operates as follows:

1. Pulsar® Plus Briquettes are placed in a basket and suspended over the solution reservoir.
2. The control box is plugged into a chemical controller output and powered on.
3. When the chemical controller requires chlorine, the feed solenoid valve opens allowing water from the pool return to enter the inlet water manifold at the proper supply flow rate.
4. Low-velocity, high-volume water enters the reservoir and covers the bottom of the basket.
5. Pulsar® Plus Briquettes erode into the reservoir and create a consistent 0.7% available chlorine solution with 84 °F [28.8 °C] inlet water temperature.
6. The chlorinated solution fills the reservoir, lifting the float switch connected to the discharge valve until the valve opens.
7. The discharge valve and outlet tubing are connected to a venturi. The vacuum generated by the venturi suction drains the reservoir tank and sends the concentrated solution into the pool return.

2.2 Process Flow Diagram

Figure 1. Process Flow Diagram - Chlorination System

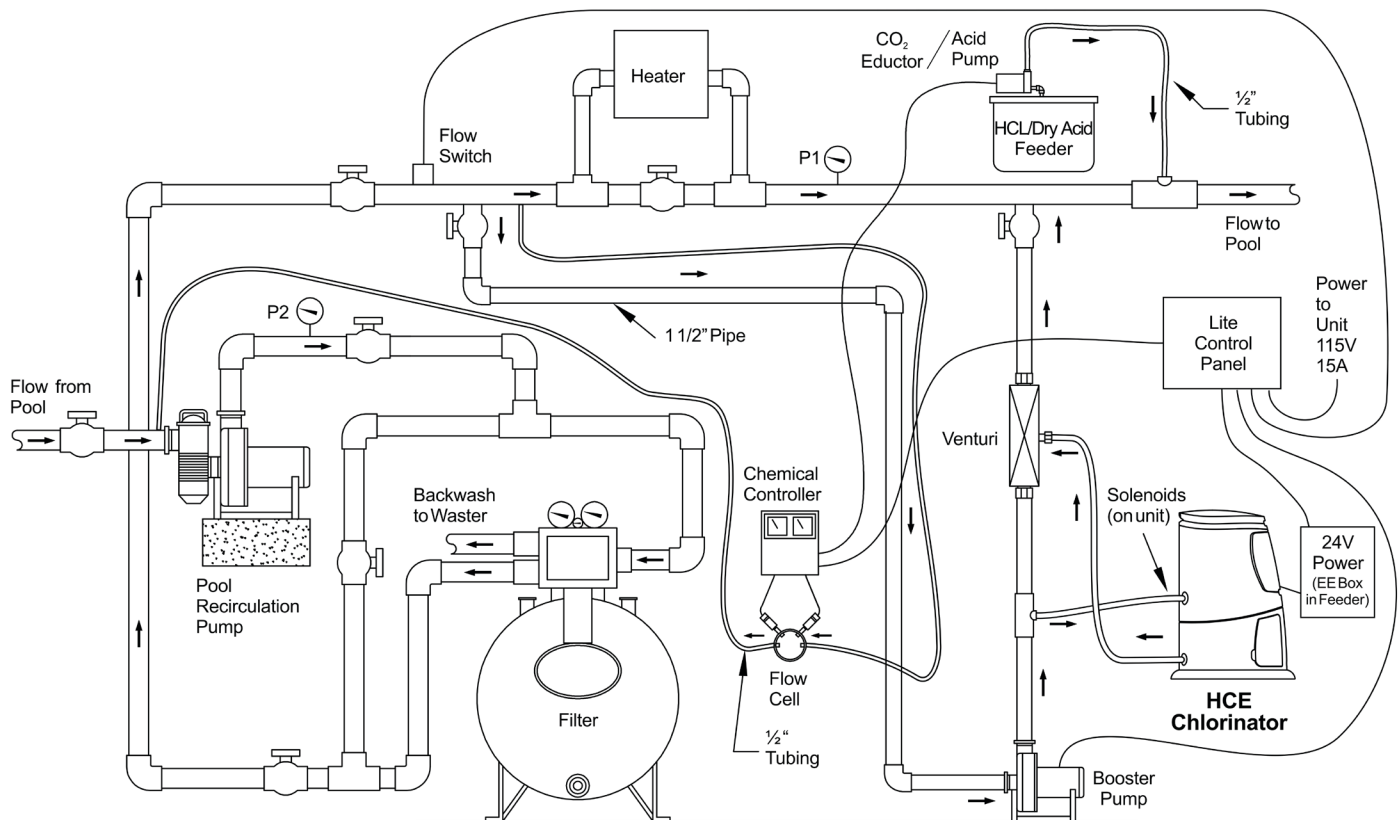

3 Pulsar® Precision Feeder Overview

Figure 2. Front View of Pulsar® Precision Feeder

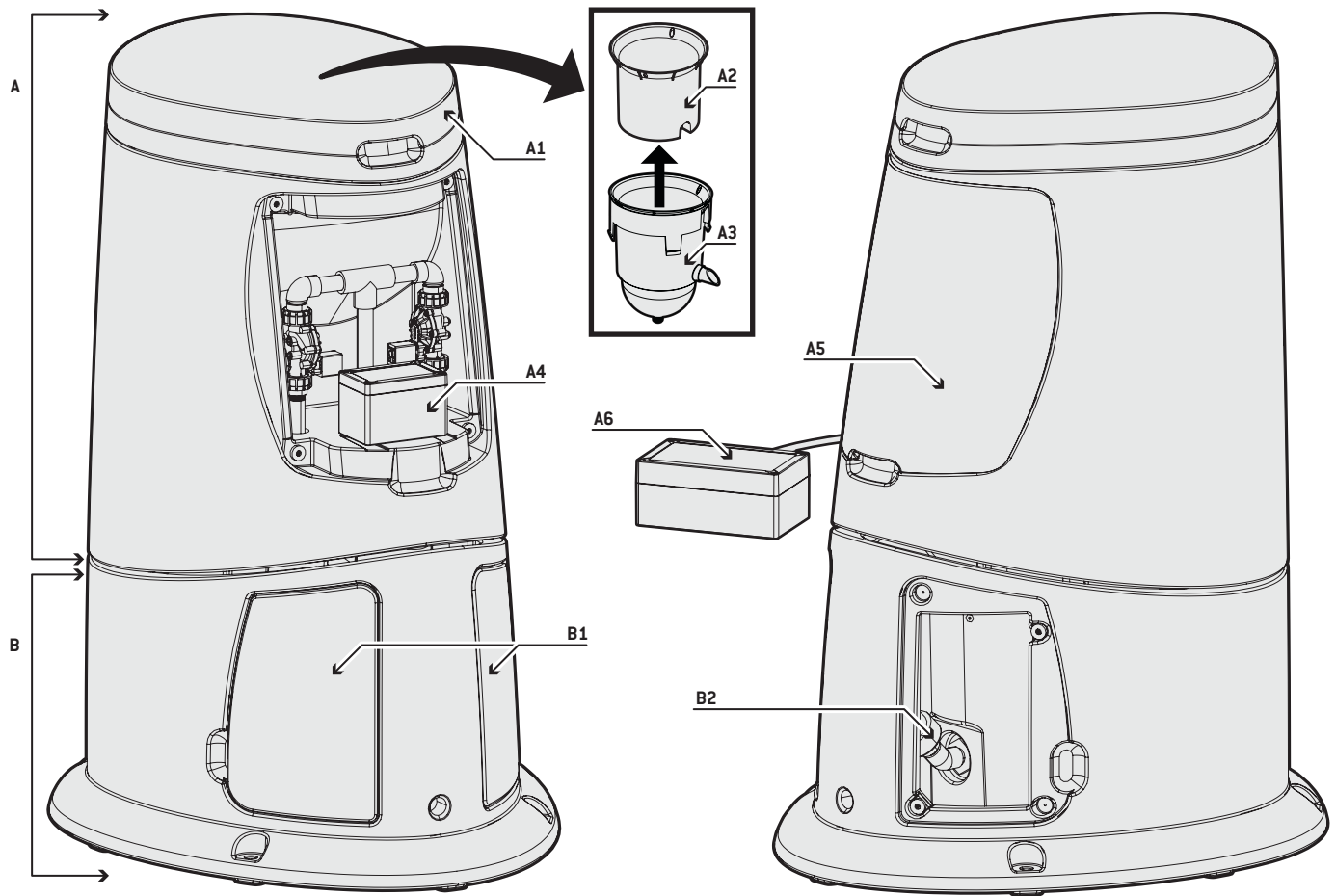

3.1 Components List

The Pulsar® Precision Feeder includes these components:

- A Hopper, which includes:
 - A1 Hopper lid, hinge pin, and retainer
 - A2 HCE grid basket
 - A3 HCE bowl
 - A4 Junction Box
 - A5 Front cover
 - A6 Feeder control box
 - A7 ESV (emergency shutoff valve)(picture not shown)
 - A8 ESV nut wrench (picture not shown)
 - A9 Grid basket removal tool (picture not shown)
- B Base, which includes:
 - B1 Left and right covers
 - B2 Discharge valve assembly
 - B3 Level switch (picture not shown)
 - B4 Bucket funnel (picture not shown)
- C Booster pump and venturi installation kit (picture not shown)

4 Pre-installation Instructions

4.1 Prepare the Site

Before installing equipment, ensure that:

1. The site has all electrical connections installed. All electrical lines should be secured to meet site safety procedures and to prevent tripping over electrical lines.

! Danger: All wiring connections, fusing, grounding, inspection, and maintenance of wiring must be performed by a licensed electrician in accordance with the National Electric Code (NEC), Occupational Safety and Health Act (OSHA) in the United States, and all local electrical codes. Failure to properly install and wire this product can result in property damage, injury, or death, and may affect warranty coverage.

2. Site meets criteria noted in Site Requirements on page 8.

4.1.1 Site Requirements

- The feeder must fit in the selected room with enough clearance for maneuvering and servicing the equipment.
 - Recommended clearance for feeder installation is 48" L x 48" W x 76" H [121.9 cm x 121.9 cm x 193.0 cm]
 - Minimum clearance for feeder installation is 36" L x 36" W x 64" H [91.4 cm x 91.4 cm x 162.6 cm].
- The room must have proper ventilation.
- The room must be climate-controlled between 40 °F – 90 °F [4 °C – 32 °C].
- Required electrical service as follows:
 - 100 - 240 V AC / 15 - 20 A dedicated outlet.
 - 50 - 60 Hz single-phase only.
 - 50 Hz systems require a locally-sourced booster pump (see booster pump section, page 11, for more information).
- Determine the inlet and outlet location of the booster pump and venturi loop.
 - It is preferable to install this loop across the heater bypass valve to maximize the pressure differential of the system to enhance performance.
 - The booster pump suction should always be downstream of the pool filter(s) to ensure the use of clean, filtered water to protect the solenoid valves. Refer to Figure 1. Process Flow Diagram - Chlorination System on page 6 for proper location of piping connections.
 - The booster pump and venturi should be located to minimize the use of 90° elbows on the venturi outlet.
- The following cable lengths need to be considered for placement of the control box and feeder:
 - The control box feeder cable is 20 ft [6 m]; the feeder will need to be within 20 ft [6 m] of the control box.
 - The ORP control cable is 20 ft [6 m]; the control box will need to be within 20 ft [6 m] of the ORP controller.
 - The flow switch cable is 32 ft [10 m]; the distance between the control box and flow switch should be considered.

4.2 Gather Equipment for Feeder Installation

Assemble these products in preparation for installation:

- Pulsar® Precision components
- Essential equipment supplied by others
- Commercial off-the-shelf (COTS) tools
- Personal Protective Equipment (PPE)

4.2.1 Pulsar® Precision Components

See the Components List on page 7.

4.2.2 Essential Equipment Supplied by Others

- 1 ½" Sch 40 pipe
- Two (2) 1 ½" ball valves
- 1 ½" Sch 40 elbows, 45° and 90°
- 1/2" [1.27 cm] flexible tubing
- PVC primer and glue
- Saddle clamps for connection to 1 ½" PVC pipe from pool return (optional)
- Plumber's tape

4.2.3 COTS Tools

- Drill
- 1 ¾" hole saw and 1 ½" NPT tap (optional)
- 11/16" drill bit and 1/2" NPT tap
- Saddle clamps (optional)
- Pipe wrenches or gas pliers
- Tubing cutters
- Saw (to cut PVC pipe)

4.2.4 PPE

- Safety glasses
- Rubber gloves
- Apron

4.3 Pre-Installation Checklist

Table 1. Pre-installation Checklist

Item No	Check	Completed?
1	Is a licensed electrician available to perform necessary electrical wiring of the booster pump?	
2	Does the site meet all criteria noted in Section 4.1.1, Site Requirements on page 8?	
3	Have inlet and outlet locations on the pool return post filter been identified?	
4	Are all Pulsar® Precision components on hand?	
5	Is all essential equipment supplied by others on hand?	
6	Are all COTS tools and other equipment on hand?	
7	Is all PPE on hand?	

5 Installation Instructions

5.1 Install the Booster Pump- Venturi Loop

Downstream of your pool filter(s), connect the booster pump suction and venturi outlet 1 ½" piping: See Figure 3.

⚠ Caution: Shut off the pool pump and isolate the pool return piping location used for the installation to prevent excessive water leakage.

Note: Refer to the Figure 1. Process Flow Diagram - Chlorination System on page 6 for proper location of system piping connections.

1. Drill and tap two 1 ½" NPT holes that will be used for the booster pump inlet and venturi outlet, respectively.

Note: Saddle clamps or tee's can be used as an alternative for a cleaner installation.

2. Since not all pipes run full, for horizontal pipe, drill the holes on the side or bottom.
3. Cut the 12" x 1 ½" PVC threaded nipple provided in the installation kit in half.
4. Apply plumber's tape to the threads of the two nipples and thread the nipples into the 1 ½" tapped holes.
5. Add silicon seal bead around the thread connection to help make a waterproof seal.
6. Take the 1 ½" ball valves and glue them onto the 1 ½" nipples. These are the isolation valves to the inlet and outlet of the booster pump and venturi.
7. Glue the 2" x 1 ½" reducer bushings to the pump union tailpieces and connect to the booster pump suction and discharge.
8. Apply plumber's tape to the venturi threads and thread the 1 ½" unions to both ends of the venturi.
9. Thread the 3/4" x 1/2" reducer coupling onto the venturi suction.
10. Complete the 1 ½" piping run from the inlet nipple to the booster pump suction.
11. Connect the discharge of the booster pump with the 1 ½" to 1/2" reducer bushing and the 1 ½" venturi ensuring the venturi is oriented in the direction of flow.
12. Complete the 1 ½" piping run from the outlet of the venturi to the outlet nipple on the pool return using as few 90° elbows as practicable. The use of 45° elbows in place of 90° elbows are preferred to minimize backpressure on the venturi outlet.

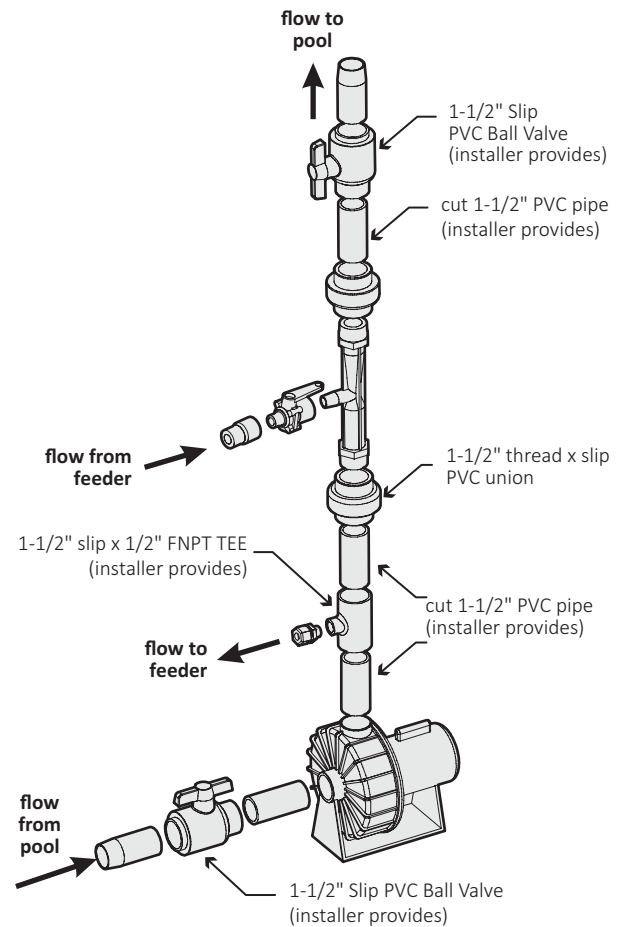

Figure 3. Complete the 1 ½" piping run

5.2 Install the Flow Switch

Install the flow switch upstream of the booster pump suction in horizontal or vertical pipe with upward flow direction:

1. Drill and tap a 1/2" NPT hole just upstream of the booster pump suction.
2. In horizontal pipe, the tapped hole should be on the side parallel to the ground or a little lower to ensure the positive presence of flow.
3. In the vertical pipe, the tapped hole should be in the upward direction of the flow.

⚠ Caution: Do not install the flow switch on top of the pipe or in vertical piping with flow going down. This may cause false "no flow" readings in pipes that don't always run full.

4. Use sufficient plumber's tape on the flow switch threads to ensure a good seal.

5.3 Feeder Setup- Connect the Discharge Tubing Line

To connect the discharge tubing line of the feeder to the venturi suction:

1. Remove the hopper (top half) of the feeder and place it on the floor.
2. Remove the left and right base covers to expose the discharge piping check valve and tubing connector.
3. Estimate how much tubing needed to make the connection between the feeder and venturi and cut the appropriate tubing length using tubing cutters.
4. Manipulating the feeder base for easier access, connect the ½" OD polyethylene tubing to the tubing connector.
5. Wind the other end of the tubing through the hole in the base so that it comes out of the back of the base. See Figure 4.
6. Connect the tubing to the tubing connector on the venturi suction.
7. Use a wrench, if necessary, to secure the tubing onto the tubing connectors.

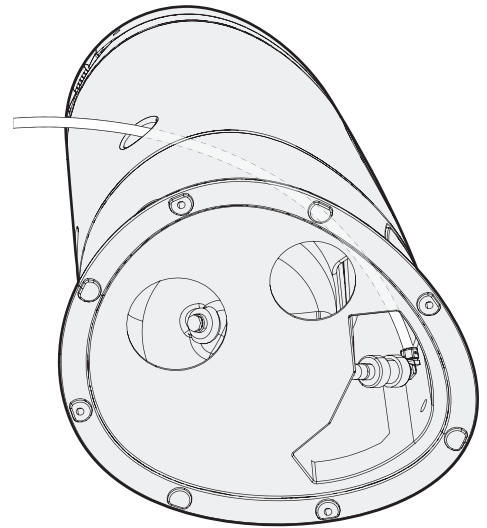

Figure 4. Discharge Tubing Connection

5.4 Feeder Setup- Connect the Inlet Tubing Line

To connect the inlet tubing line of the feeder to the inlet manifold:

1. Replace the hopper back onto the feeder base.
2. Install the 1/2" ball valve and strainer at the booster pump, discharge prior to the venturi.
3. Estimate how much tubing is needed to make the connection between the feeder and venturi and cut the appropriate tubing length using tubing cutters.
4. Using the appropriate tubing connectors, connect the feeder inlet to the booster pump discharge.

5.5 Mount the Control Box

Open the control box cover to access the mounting holes of the control box.

1. The control box mounting holes are located on the outside of the watertight gasket.
2. Select the proper bolt size and material for compatibility to box and wall construction.

5.6 Wire the Booster Pump to the Control Box

Using a certified electrician, connect the booster pump to the control box using 12 AWG or bigger wire.

Warning: Risk of dangerous or fatal electrical shock. Be sure that power to the motor circuit is off before working on wiring, wiring connections, or the motor. Re-install the motor end cover and all other wiring covers before turning on the power.

Note: The pump must be permanently connected to the control box. Be sure no other lights or equipment are on the same circuit.

Note: Be sure no other lights or equipment are on the same circuit as the control box.

Note: Use Ground Fault Circuit Interrupter (GFCI) as a master on-off switch.

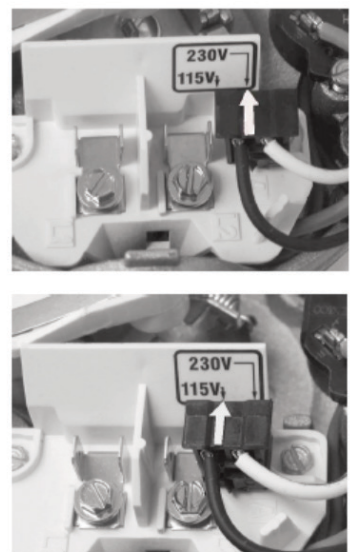

Figure 5. Wire the Booster Pump

1. Refer to Appendix section 10.2.1 and 10.2.2 for control box wiring help.
2. Remove the booster pump motor end cover to expose the pumps dual-voltage selector.
3. If you have 230 V motor supply voltage, confirm that the plug is set for 230 V. The arrow on the plug will point to the 230 V position, which is the default position of the pump (the plug only connects with one prong in this position).
4. If you have 115 V supply, pull the plug straight up and place it on the two brass prongs so that the arrow points to the 115 V position.
5. Open the control box cover and wire the booster pump to the control box using the wiring diagram, Figure 5.
6. Replace the booster pump motor end cover to complete the booster pump wiring.

5.7 Connect the Flow Switch Cable

Connect the orange flow switch cable to the flow switch:

1. Route the flow switch cable so that it is not a tripping hazard.
2. The M12 connector on the cable goes in one direction. Screw in the connector so that it fully engages with the flow switch.

5.8 Prime the System

1. Allow pool water to enter the 1 ½" and 1/2" piping and tubing to confirm overall water tightness.
2. Open the 1 ½" inlet ball valve and allow water to enter the booster pump checking for leaks.
3. Slowly crack open the booster pump discharge union, allowing water to flow out confirming that the booster pump is fully primed.
4. Reconnect and tighten the discharge union.
5. Open the 1 ½" outlet ball valve fully priming the entire booster pump / venturi loop.
6. Open the 1/2" gray inlet and outlet feeder ball valves, allowing water to reach the feeder.
7. Check for leaks at the booster pump and venturi loop and feeder and flow switch. Redo any leaking connections.

6 Post-Installation Instructions

Before first time startup of the feeder, check:

Table 2. Post-Installation Checklist

Item No	Check	Completed?
1.	Is there any residual debris (plastic shavings, screws, and so on) inside the solution tank?	
2.	Has the booster pump been fully primed?	
3.	Are all electrical lines secure and not a tripping hazard?	
4.	Are all exposed electrical and instrument lines protected and do they meet field conditions?	
5.	Does the booster pump motor plug line up to the correct voltage supply?	
6.	Is the control box cover closed and screws securely tightened?	
7.	Are all fittings and unions tightened to prevent leaks?	
8.	Are flow directional arrows pointed in the correct direction of flow on the venturi, solenoid valves, and check valves?	
9.	Is grid basket placed in HCE bowl correctly so that it cannot spin around?	

6.1 System Startup

Note: Before starting up the equipment, ensure that the Post-Installation checklist has been completed.

6.1.1 Feeder Preparation

After completing the post-installation checklist:

1. Put on the appropriate PPE: long sleeved clothing, rubber gloves, apron, dust mask, and safety glasses.

 **Danger:** Use suitable personal protective equipment (PPE) at all times to avoid physical contact with calcium hypochlorite liquid or vapor. Failure to do so may result in death or serious injury. Please refer to the Safety Data Sheet for additional information and precautions regarding the proper handling of calcium hypochlorite.

2. Open the hopper lid.
3. Place grid basket into the tank.
4. Use a scoop to add approximately 3 inches of Pulsar® Plus Briquettes to the basket.
5. Close the hopper lid.

6.1.2 Control Box Preparation

Danger: Ensure the control box is not plugged into power prior to removing the top cover, adjusting DIP switches, and wiring in the booster pump. Failure to do so may result in death or serious injury from electrical shock.

1. Prior to powering up the control box, verify the output setting and economy mode by removing the top cover and identifying the DIP switch settings in accordance with the Feed Cycle Settings table in step 4, below.
2. The DIP switches are located near the top left of the controller and the feed cycle settings are on the top right. See Figure 6, below.
3. There are 4 DIP switches. Switches 1, 2, 3 control the feed solenoid On/Off time and switch 4 turns the economy mode On/Off.

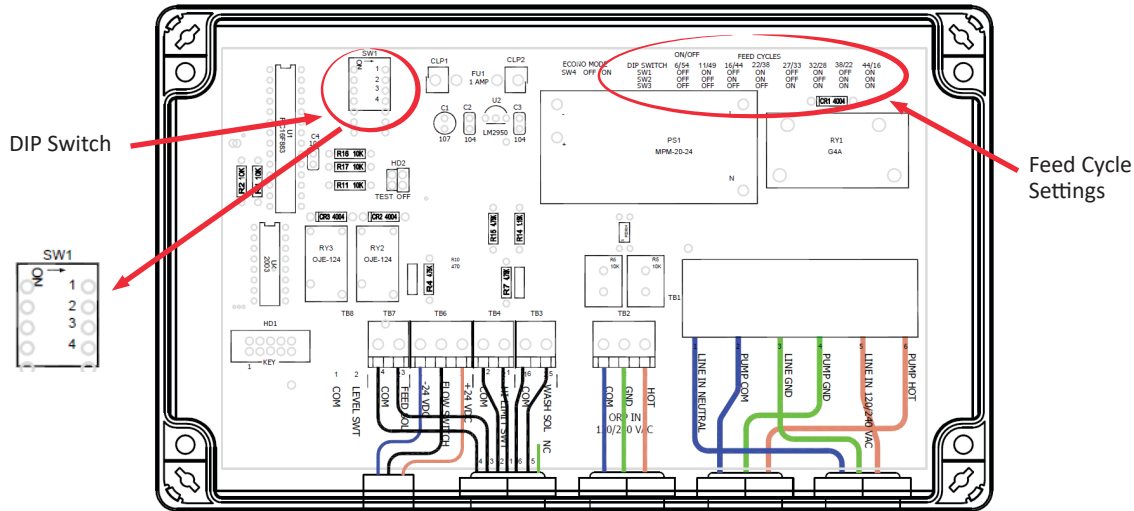

Figure 6. DIP Switch Location and Feed Cycle Settings

4. The below Feed Cycle Settings table shows On/Off feed times in seconds based on the combination of DIP switch settings. The higher on times yield higher chlorine output.

ON/OFF	FEED CYCLES							
DIP SWITCH	6/54	11/49	16/44	22/38	27/33	32/28	38/22	44/16
SW1	OFF	ON	OFF	ON	OFF	ON	OFF	ON
SW2	OFF	OFF	ON	ON	OFF	OFF	ON	ON
SW3	OFF	OFF	OFF	OFF	ON	ON	ON	ON

5. Set your desired output and economy mode setting in accordance with the above Feed Cycle Settings table.
 - a. For example, SW1 on, SW2 off, SW3 on yields 32 sec On and 28 sec Off for the feed solenoid – Approximately 75% chlorine output of the feeder.
 - b. If SW4 is off, the booster pump will be always on. If SW4 is on, the booster pump will run in economy mode and stop 20 sec after the last feed or wash cycle (or 5 min if the pump just started up).
 - c. The DIP switches can be toggled at any time with the controller powered off.
6. Close the top cover of the controller to resume start up.

6.1.3 System Power Up

To power up the system:

1. Connect the control box to a dedicated AC power source in accordance with the site requirements section 4.1.1.
2. After a 30 sec boot-up period, the box will power up with the indicator lights turning on. Confirm the following indicator lights are on:
 - Power : red/off.....A red OFF indicator light means the box is powered and on standby.
 - Mode : green/ORP or MANUAL.....Indicates the last operating mode the control box was in.
 - Flow : green.....Indicates there is flow in the pool recirculation piping. If there is no light, there is either no flow in the piping, the orange flow switch cable is not correctly connected to the flow switch, or the flow switch is bad.
 - FEED, WASH, ALERT.....Off when the power is on Off.
3. Slowly open the inlet ball valve to allow water to flow through the manifold.
4. Press the control box power button to energize the system.
5. Put the control box on manual mode to energize the feed solenoid valve and send water into the hopper.
6. Check for leaks from lines, valves, and connections. If necessary, tighten parts.
7. Put the control box back on ORP mode.
8. Connect the control box ORP plug to an ORP (chemical controller) chlorine demand output.
9. Use the ORP controller to send a chlorine feed signal to confirm operation of the Pulsar® Precision control box.
10. When the chlorine signal is removed, verify that the controller goes into four wash cycles of 15 sec On and 15 sec Off.
11. Once all operating conditions are verified, press the power button on the control box to put it back into standby.

7 Operation Instructions

Note: Before starting up the equipment, ensure that the Post-Installation checklist has been completed.

To operate the Pulsar® Precision Feeder:

1. Put on the appropriate PPE: long sleeved clothing, rubber gloves, apron, dust mask, and safety glasses.

 **Danger:** Use suitable personal protective equipment (PPE) at all times to avoid physical contact with calcium hypochlorite liquid or vapor. Failure to do so may result in death or serious injury. Please refer to the Safety Data Sheet for additional information and precautions regarding the proper handling of calcium hypochlorite.

2. Ensure that the inlet and outlet ball valves on the booster pump discharge and venturi suction lines are closed.
3. Open the hopper lid.
4. Ensure that the hopper is at least 50% full with Pulsar® Plus Briquettes.
5. Close the hopper lid.
6. Slowly open the feeder inlet and outlet 1/2" ball valves.
7. Turn on the master power button on the control box. Select or verify the feed mode if running in manual or off of an ORP controller.
 - If the control box is plugged into an ORP powered receptacle, press the mode button to put the control box on ORP mode.
8. If on ORP, once chlorine demand is received, the booster pump will turn on and the feeder will start its feed cycle based on the defined DIP-switch setting.
9. Once chlorine demand terminates, the feeder will go into its wash 15 sec On/Off cycle.
10. If more water goes into the feeder than is able to be removed by the venturi, the alert indicator light will come on indicating a high level condition. This condition will shut both solenoid valves and allow the booster pump to continue to run to let the venturi remove the water from the base.
 - If the pump was off due to economy mode, it will turn on in order to let the venturi remove water from the base.
 - The ESV (Emergency Shutoff Valve) provides mechanical stop in case the electronic high level switch malfunctions.
11. If Economy mode is selected, the booster pump will shut off after a period of time when no chlorine is demanded by the ORP and the wash cycle has completed.

7.1 Fill the Hopper

1. Put on the appropriate PPE: long sleeved clothing, rubber gloves, apron, dust mask, and safety glasses.

 **Danger:** Use suitable personal protective equipment (PPE) at all times to avoid physical contact with calcium hypochlorite liquid or vapor. Failure to do so may result in death or serious injury. Please refer to the Safety Data Sheet for additional information and precautions regarding the proper handling of calcium hypochlorite.

2. Open the hopper lid.
3. Use a scoop to fill the hopper with Pulsar® Plus Briquettes.

 **Caution:** Do not dump Pulsar® Plus Briquettes into the basket. Dumping will cause dust from calcium hypochlorite and can damage basket from force of load.

 **Caution:** Use of any briquettes or other chemicals other than the Pulsar® Plus Briquettes designed for use with this chlorinator shall void this warranty.

4. Close the hopper lid.

7.2 Fill the Hopper (Dustless Procedure)

Danger: Use suitable personal protective equipment (PPE) at all times to avoid physical contact with calcium hypochlorite liquid or vapor. Failure to do so may result in death or serious injury. Please refer to the Safety Data Sheet for additional information and precautions regarding the proper handling of calcium hypochlorite.

1. Put on the appropriate PPE: long sleeved clothing, rubber gloves, apron, dust mask, and safety glasses.
2. Remove the red tamper prevention tab on the lid of the briquette bucket. The lock release button is visible.
3. Firmly press the lock release up, then turn the lid counter-clockwise to remove the lid from the bucket.
4. Place the bucket funnel on the bucket opening and turn it clockwise until the bucket funnel is firmly seated on the bucket. Listen for the ratcheting sound of the locking mechanism to confirm that the funnel is properly installed.
5. In one smooth motion, invert the bucket into the hopper opening while aligning the tabs of the bucket funnel into the slots of the hopper opening. See Figure 7, below.

Figure 7. Bucket Funnel Installation

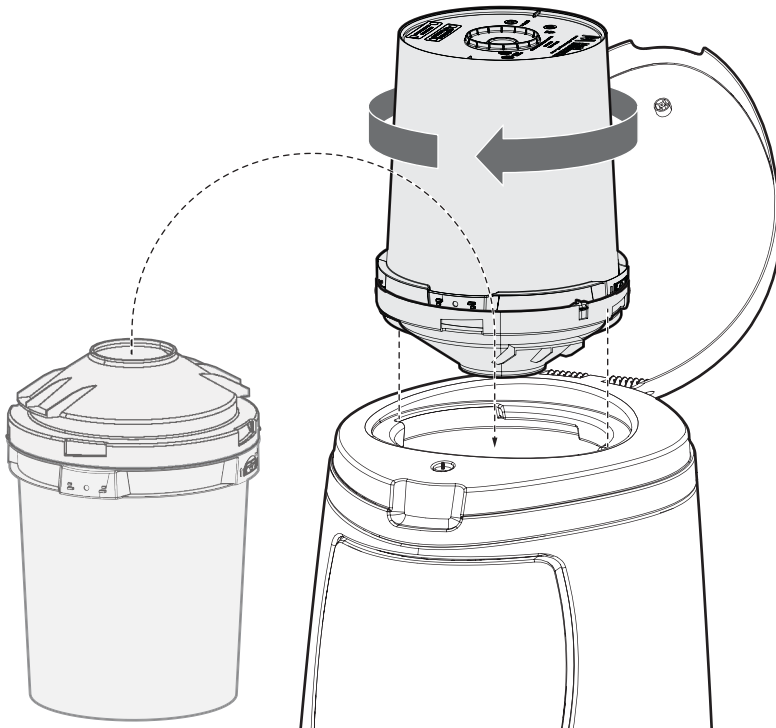

6. Turn the bucket and funnel clockwise to secure the bucket onto the hopper. The Pulsar® Plus Briquettes will deposit into the hopper.

Note: Ensure that the bucket is empty before removing it from the hopper.

To remove the bucket from the hopper:

1. Turn the bucket counter-clockwise to disengage the tabs on the bucket funnel from the hopper.
2. Lift the bucket and funnel up to remove them from the hopper.
3. To remove the bucket funnel from the bucket, firmly press up on the two funnel locking buttons, then turn the bucket funnel counter-clockwise. See Figure 8.

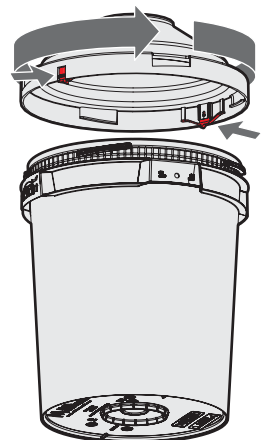

Figure 8. Bucket Funnel Removal

8 Preventative Maintenance

8.1 Preventative Maintenance Schedule

Complete each of the following tasks during the first week of each month.

Table 3. Monthly Maintenance

Action Needed	Maintenance Process	Time to Complete
Change/clean basket	See Clean the Grid Basket (Online Cleaning Instructions) on page 19.	
Inspect inlet and outlet plumbing fittings	<p>Verify that there are no leaks at any of the inlet and outlet ½" feeder fittings and 1 ½" booster pump and venturi piping and fittings, including the booster pump itself.</p> <ol style="list-style-type: none"> 1. Close all isolation ball valves and re-plumb / replace any leaking piping and fittings. 2. If leaking is observed at the pump motor, the pump shaft seal and impeller will have to be replaced. Refer to the pump manual in the Appendix, page 23, for replacement parts and instructions. 	2 min
Inspect booster pump	<ol style="list-style-type: none"> 1. Visually check for leaks on and around the pump, including the suction and discharge piping and fittings. 2. Close inlet and outlet 1 ½" ball valves and tighten or replace any leaking fittings. 3. If leaking observed at the pump motor, the pump shaft seal and impeller is likely burned. 4. Refer to the pump manual in the Appendix, page 23, for replacement parts and instructions. 	5 min
Inspect inlet line strainer assembly	<ol style="list-style-type: none"> 1. With pressure in the line, visually inspect the strainer basket for leaks. Replace the entire basket assembly if leaking. 2. Close inlet ball valve. 3. Remove strainer basket and visually inspect for cracks and debris. 4. Remove strainer screen and wash it out prior to replacing it back into the basket. 5. If screen appears damaged or has a hole in it, replace with a new screen. 6. Re-install the strainer basket back into the strainer body. 	10 - 15 min
Inspect discharge check valve	<ol style="list-style-type: none"> 1. Close the outlet ball valve. 2. Open the lower left and right base covers and unscrew the check valve unions to remove the check valve body. 3. Disassemble the check valve and inspect for calcium build up and debris. Clean if necessary. 4. Visually check the seal for corrosion. If the seal is corroded, replace the check valve. 5. Re-assemble the check valve body ensuring to put the seal on the side of the ball. 6. Replace the check valve body back onto the unions, ensure arrow points away from the feeder. 	10 min
Inspect reservoir tank	<p>Visually inspect the solution reservoir and ensure that there is no calcium buildup or debris on the high level switch or the discharge valve (DV) assembly including the DV float, and arm.</p> <ul style="list-style-type: none"> ▪ Buildup on the level switch will prevent positive notification of a high level event. Verify level switch operation by lifting up the switch and confirming the alert indicator light turns on. ▪ Build up on the DV float or arm can interfere with feeder discharge operation. Refer to cleaning instructions on page 19 if needed. 	5 min
Inspect 45° cut Bowl drain pipe	<ul style="list-style-type: none"> ▪ Visually inspect the HCE bowl drain pipe and ensure that there is no calcium build up or debris on around the edges clogging the fluid path. Break off scale if necessary. 	

Complete the following tasks during the first week of January and the first week of July.

Note: Maintenance that prevents the discharge line from clogging is critical to feeder operation.

Table 4. Semiannual Maintenance

Action Needed	Maintenance Process	Time to Complete
Inspect the Venturi	<ol style="list-style-type: none">1. Close the inlet and outlet 1 ½" ball valves to the booster pump suction and venturi outlet2. Close the inlet and outlet 1/2" ball valves to the feeder.3. Disconnect the feeder discharge tubing from the venturi.4. Remove the venturi via the 1 ½" unions and visually inspect and verify it is not clogged with scale build up.5. If scale buildup is found, refer to cleaning instructions on page 19.	2 - 5 min
Inspect the solenoid valves	During feed or wash cycle, if the solenoid valves are hot to the touch, consider rebuilding or replacing the valve. If the solenoid makes a rattling noise when energized, consider rebuilding or replacing the valve.	2 min

8.2 Cleaning Procedures

8.2.1 Equipment Needed

- PPE
 - Rubber gloves
 - Apron
 - Safety glasses
 - Long sleeved clothing
- Two 5-gallon buckets for online cleaning
- Three 5-gallon buckets for offline cleaning
- Basket removal tool
- Replacement basket
- Muriatic acid
- Hose (for offline cleaning)

8.2.2 Clean the Grid Basket (Online Cleaning Instructions)

 **Warning:** Always label the contents of cleaning buckets.

 **Danger:** Use suitable personal protective equipment (PPE) at all times to avoid physical contact with calcium hypochlorite liquid or vapor. Failure to do so may result in death or serious injury. Please refer to the Safety Data Sheet for additional information and precautions regarding the proper handling of calcium hypochlorite.

1. Put on the appropriate PPE: long sleeved clothing, rubber gloves, apron, and safety glasses.
2. Allow the hopper to run low enough so all remaining Pulsar® Plus Briquettes in the hopper fit inside the basket.
3. Add water to two 5-gallon buckets until each bucket is approximately 3/4 full.

4. Prepare the soak bucket:
 - a. Carefully add 12 oz of muriatic acid to one of the 5-gallon buckets to create a roughly 1% solution of 20 Baume muriatic acid.

 **Warning:** Always be careful when adding muriatic acid to water; this combination creates an exothermic reaction, which gives off heat. Failure to take care may result in serious injury.

- b. Label this bucket "ACID" and set it aside so that it will not be knocked over.
5. Label the remaining bucket "FRESH WATER" and set it aside.
6. Close the feeder inlet and outlet 1/2" ball valves.
7. Turn off the control box master power switch.
8. Use basket removal tool to remove the used grid basket from the chlorinator. If necessary, use a flat head screw driver to pry and jostle the basket to break scaling.
9. If necessary, break off excess scale off of the HCE Bowl 45° cut drain pipe.
10. Pour any remaining Pulsar Plus Briquettes into the replacement basket and install the basket and chemical into chlorinator.
11. Place the used basket into the FRESH WATER bucket.
12. Slowly open the inlet manifold ball valve.
13. Turn on the control box master power switch.
14. Shake the used basket up and down in the FRESH WATER bucket to remove loose residue.
15. Transfer the used basket to the acid bucket and let it soak for 24 hours.

8.2.3 Comprehensive (Offline) Cleaning Instructions

 **Warning:** Always label the contents of cleaning buckets.

1. If possible, allow the hopper to run completely out of Pulsar® Plus Briquettes.
2. Add water to three 5-gallon buckets until each bucket is approximately 3/4 full.
3. Prepare the soak bucket:
 - a. Carefully add 12 oz of muriatic acid to one of the 5-gallon buckets to create a 1% solution of muriatic acid.

 **Warning:** Always be careful when adding muriatic acid to water; this combination creates an exothermic reaction, which gives off heat. Failure to take care may result in serious injury.

- b. Label this bucket "ACID FOR SOAKING" and set it aside so that it will not be knocked over.
4. Prepare the rinse bucket:
 - a. Carefully add 32 oz of muriatic acid to another 5-gallon buckets.

 **Warning:** Always be careful when adding muriatic acid to water; this combination creates an exothermic reaction, which gives off heat. Failure to take care may result in serious injury.

- b. Label this bucket "RINSE ACID" and set it aside so that it will not be knocked over.
5. Label the remaining bucket "FRESH WATER" and set it aside.
6. Close the booster pump and venturi inlet and outlet 1 1/2" ball valves.
7. Close the feeder inlet and outlet 1/2" ball valves.
8. Turn off the control box master power switch.
9. Remove the drain pipe from the HCE bowl and use the basket removal tool to remove the used grid basket from the chlorinator. If necessary, use a flat head screw driver to jostle the basket to break scaling.

10. Place the used basket and drain pipe into the FRESH WATER bucket.
11. Shake the used basket up and down in the FRESH WATER bucket to remove loose residue.
12. Transfer the used basket and drain pipe to the ACID FOR SOAKING bucket and let it soak for 24 hours.
13. Remove the venturi from the union connection and place it in the ACID for soaking bucket and let it soak for 1 hr.
14. Pour the contents of the RINSE ACID bucket into the hopper of the feeder.
15. After 1 hour, check the chlorinator and tank. If both are still heavily scaled:
 - a. Carefully pour another 32 oz of muriatic acid into the hopper.
 - b. Add 32 oz of clean water to the hopper.
 - c. Check the chlorinator and tank again in another hour.
16. After 1 hour, check the venturi. If it is still scaled, add some more acid and water in the soaking bucket and allow to soak for another 30 min to 1 hour. Once the venturi is confirmed clean, re-install at the 1 ½" unions.
17. After the feeder is clean, open the 1/2" outlet ball valve on the venturi suction allowing it to remove the contents of the tank.
18. Inspect the hopper and solution tank for cleanliness.
19. Pour additional fresh water into the hopper, if necessary, to remove any debris remaining in the hopper or tank.
20. After the feeder has drained, close the outlet 1/2" ball valve.
21. Dry the inside of the hopper.
22. Install the replacement basket and drain pipe and place Pulsar® Plus Briquettes into the hopper.
23. Follow the Operation Instructions on page 16 to restart the unit.

9 Troubleshooting Guide

Symptom	Probable Cause	Solution
No/low inlet water flow	Solenoid valve does not properly open	Replace or rebuild solenoid valve. Check with dealer.
	1/2" Inlet ball valve closed	Open the inlet ball valve.
	Inlet strainer plugged	Clean inlet strainer.
	Booster pump not running	See booster pump section.
	Emergency Shut Off Valve in Closed position.	If ESV is stuck, lower gently to reset.
Insufficient chlorine in pool	Feeder empty	Refill hopper with Pulsar® Plus Briquettes.
	No/low inlet water flow	See No/low inlet water flow section above.
	Clogged discharge line	Clean or replace discharge tubing and fittings. Refer to cleaning instructions, page 19.
	Clogged check valve	Remove and clean the check valve.
	Clogged venturi	Remove venturi and clean. Refer to cleaning instructions, page 19.
Excess chlorine in pool	ORP/chemical controller problem	Refer to the ORP Controller Manual.
	Clogged basket	Clean grid basket. Refer to cleaning instructions, page 19.
	Clogged 45° cut HCE bowl drain pipe	Break off excess scale from drain pipe or remove and refer to cleaning instructions, page 19
Feeder overflow	Clogged discharge line	Clean or replace discharge tubing and fittings. Refer to cleaning instructions, page 19.
	Clogged venturi	Clean venturi. Refer to cleaning instructions, page 19.
	Insufficient outlet suction	Excessive pressure drop on the venturi outlet. Check with dealer.
	ESV Failure	Replace ESV. Check with dealer.

10 Appendix

10.1 Requirements and Specifications

10.1.1 Requirements for Product Installation and Operation

Table 5. Site Requirement

Recommended Clearance	Feeder: 48" L x 48" W x 76" H [121.9 cm x 121.9 cm x 193.0 cm]
Minimum Clearance	Feeder: 36" L x 36" W x 64" H [91.4 cm x 91.4 cm x 162.6 cm]
Water Inlet	2.5 - 3.5 gpm [9.5 - 13.2 lpm] @ 30 - 40 psig [2.1 - 2.8 bar]
Electrical	120/240 V AC, 1 ph, 50/60 Hz, 15 - 20 A

Table 6. Accessory Requirements

Chemical	Pulsar® Plus Briquettes
Discharge Tubing	1/2" [1.27 cm] OD Polyethylene flexible tubing
Water Inlet Tubing	1/2" [1.27 cm] OD Polyethylene flexible tubing

10.1.2 Product Specifications

Table 7. Operational Specifications

Dry Chemical Capacity	100 lbs + 50 lbs reserve [45.4 kg + 22.7 kg reserve] (102 lbs [46.3 kg] of available chlorine)
Tank Size (Solution Volume)	10.3 gal [39.0 L]
Available Working Solution	4.8 gal [18.2 L]
Water Inlet Size	1/2" [1.3 cm] OD
Solution Outlet	1/2" [1.3 cm] OD
Shipping Weight	Approximately 70 lbs [31.8 kg]
Operating Weight	Approximately 220 lbs [100 kg]
Operating Temperature	40 °F – 95 °F [4.4 °C – 40.6 °C]
Dimensions	29.8" L x 25.3" W x 40.9" H [75.7 cm x 64.3 cm x 103.9 cm]

Table 8. Chemical Feed Rate Specifications

Chlorine Delivery Rate (Pools)	8 – 165.0 lbs [3.6 kg – 74.8 kg] AvCl/day Maximum of 6.8 lbs [3.1 kg] AvCl/Hr
Chlorine Delivery Rate (Spas)	8 – 165.0 lbs [3.6 kg – 74.8 kg] AvCl/day Maximum of 6.8 lbs [3.1 kg] AvCl/Hr
Solution Strength	0.6 – 0.8% at 84 °F [28.8 °C] inlet water temperature
Venturi Discharge Rate	3 gpm [11.4 lpm] at nominal venturi operation

10.1.3 Optional Feed Rate Capability

Table 9. Feed Solenoid On/Off Time vs Available Chlorine Delivery Rate (lbs/day)

On/Off (seconds)	On Time %	Available Chlorine (lbs/day)	Output %
44/16	74 %	165	100 %
38/22	63 %	143	87.5 %
32/28	53 %	130	75 %
27/33	45 %	115	67 %
22/38	37 %	100	58 %
16/44	27 %	82.5	50 %
11/49	18 %	40	25 %
6/54	10 %	8	8 %

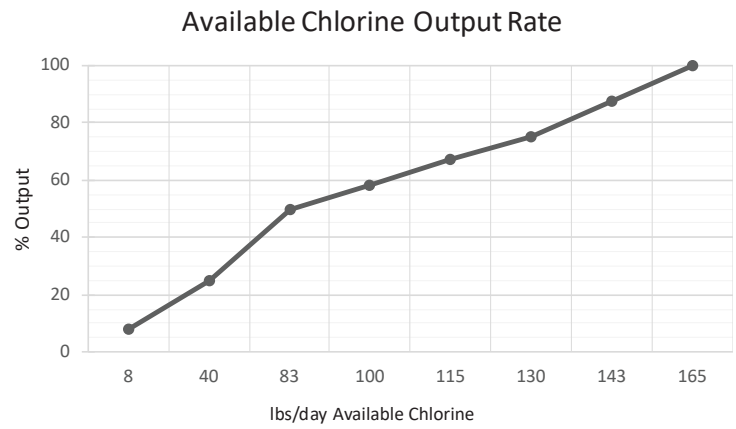

10.2 Electrical Schematics

Figure 9. 115 VAC Control Box Wiring Schematic

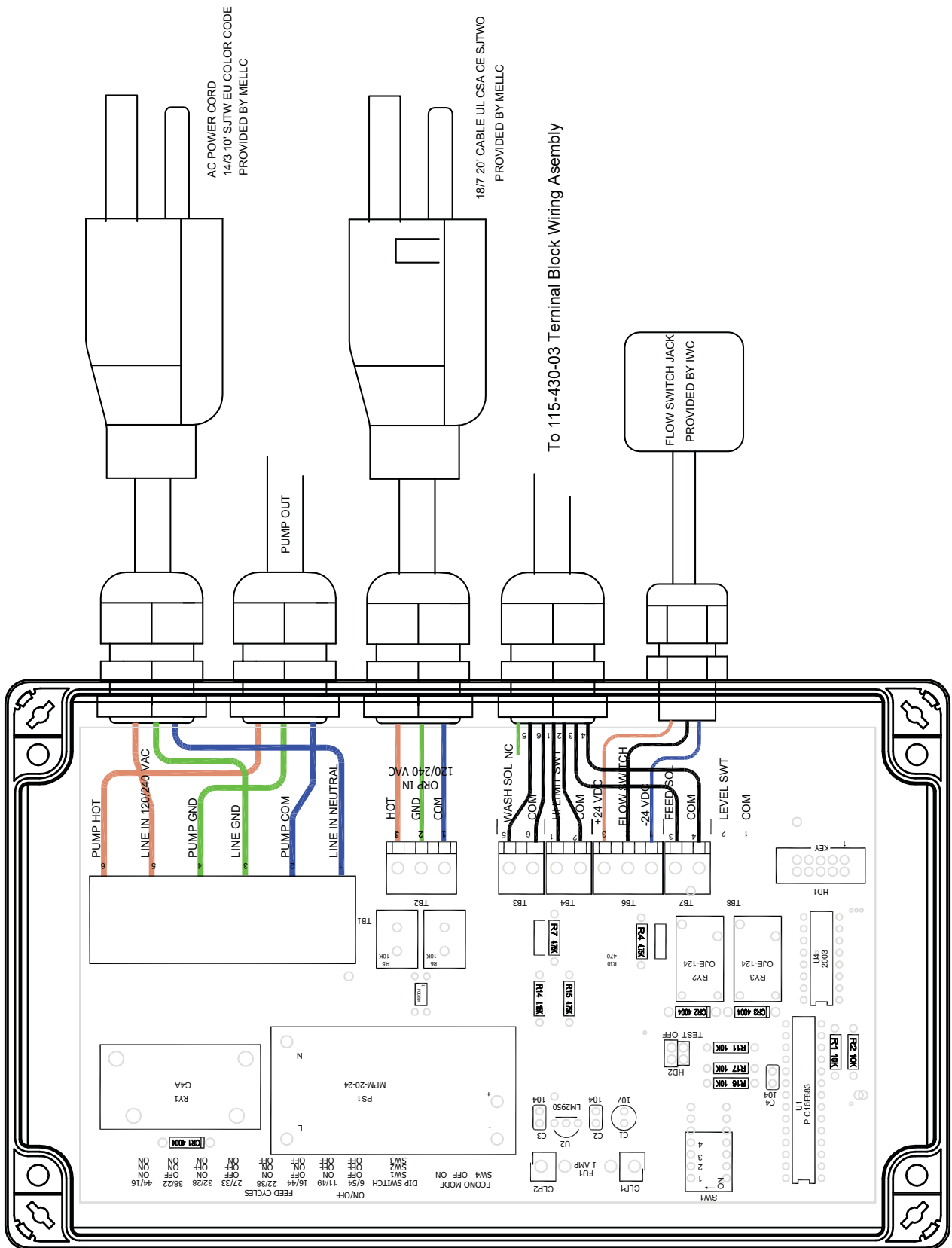

Figure 10. 230 VAC Control Box Wiring Schematic

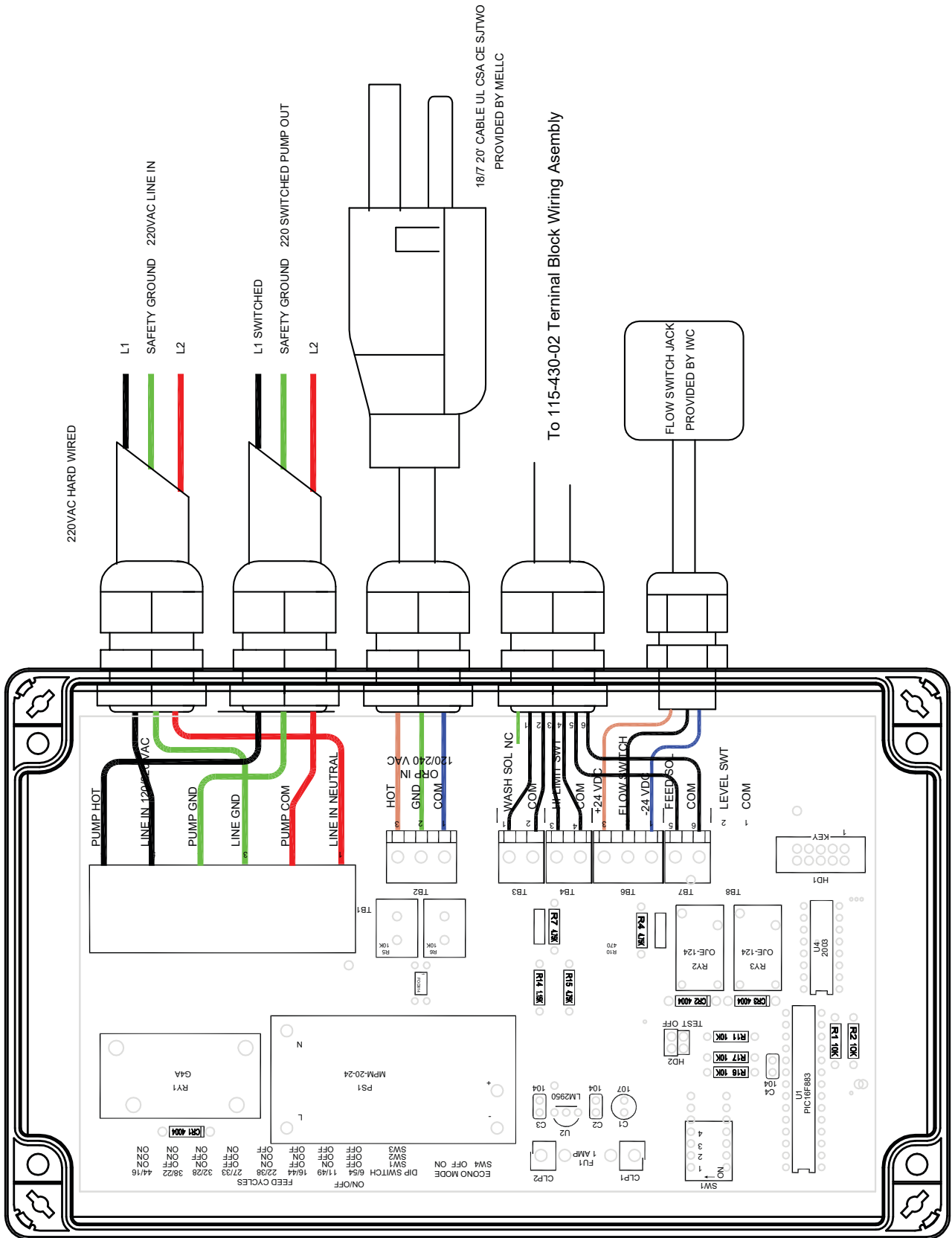
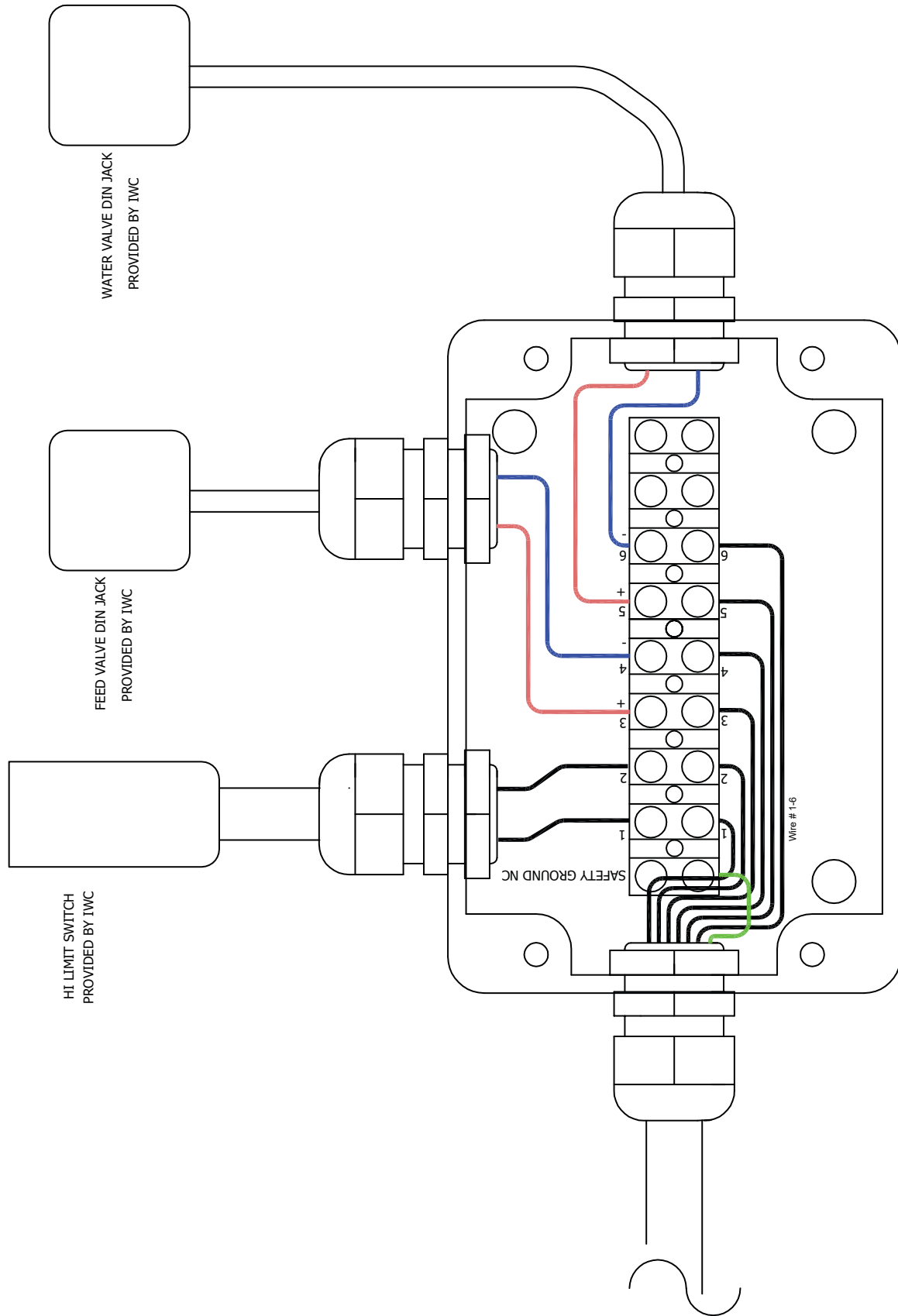
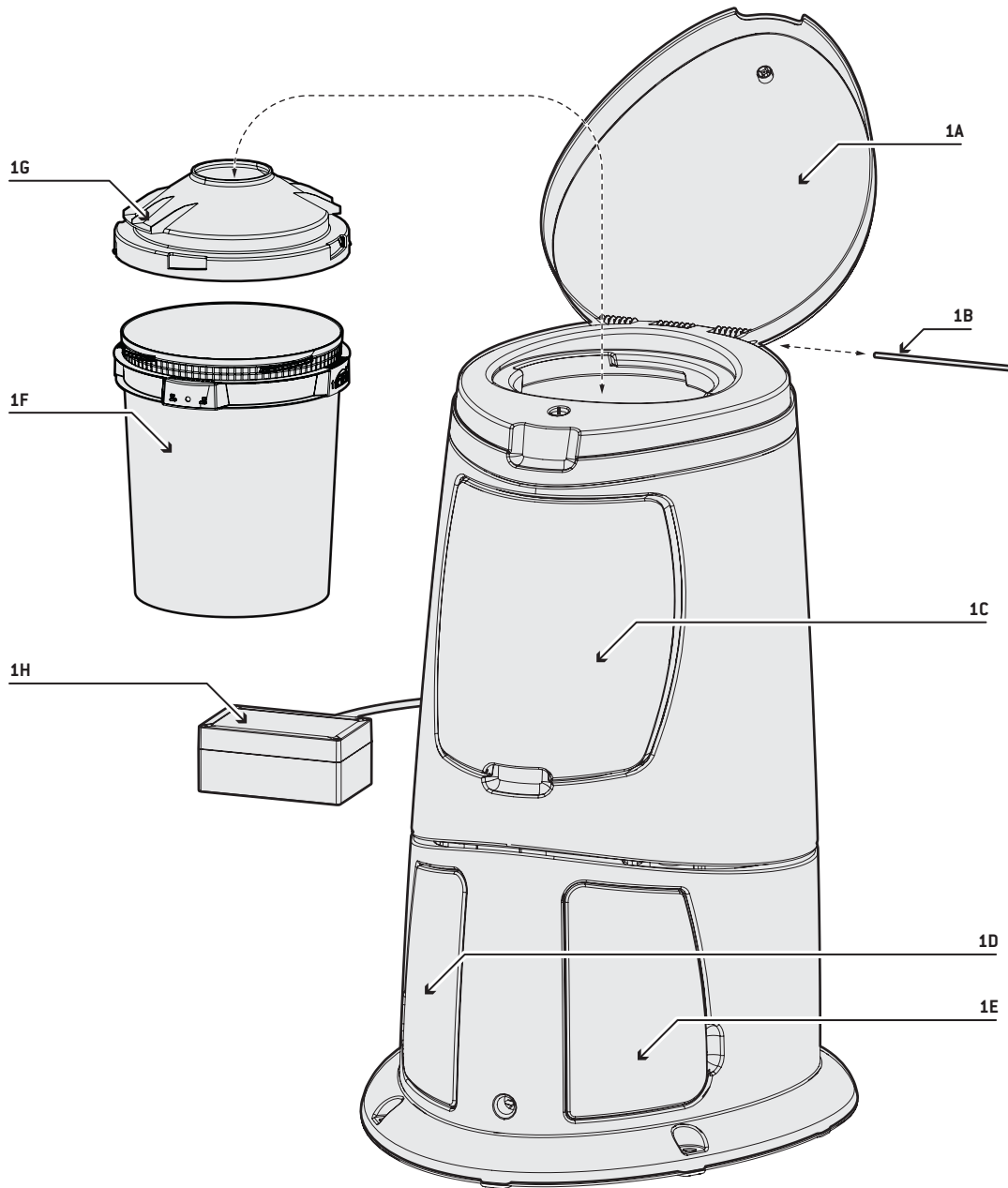

Figure 11. Feeder Junction Box Wiring Schematic



10.3 Replacement Parts List and Views

Figure 12. Hopper and Base Exterior Components View



No	Description	Part Number
1: HOPPER AND BASE EXTERIOR COMPONENTS (if applicable, use both part numbers when placing order)		
1A	Pulsar Lid / lid label	73213 / 73251
1B	Hinge Pin and Retainer Clip	N/A
1C	Pulsar Front Cover / Cover Label	73223 / 73262
1D	Left Cover	73225
1E	Right Cover	73226
1F	Bucket - 50 lbs Pulsar® Plus	30170
1G	Bucket Funnel	73215
1H	Pulsar Control Box / Control Box Label	73202 / 73245

Figure 13. Hopper Interior Components View

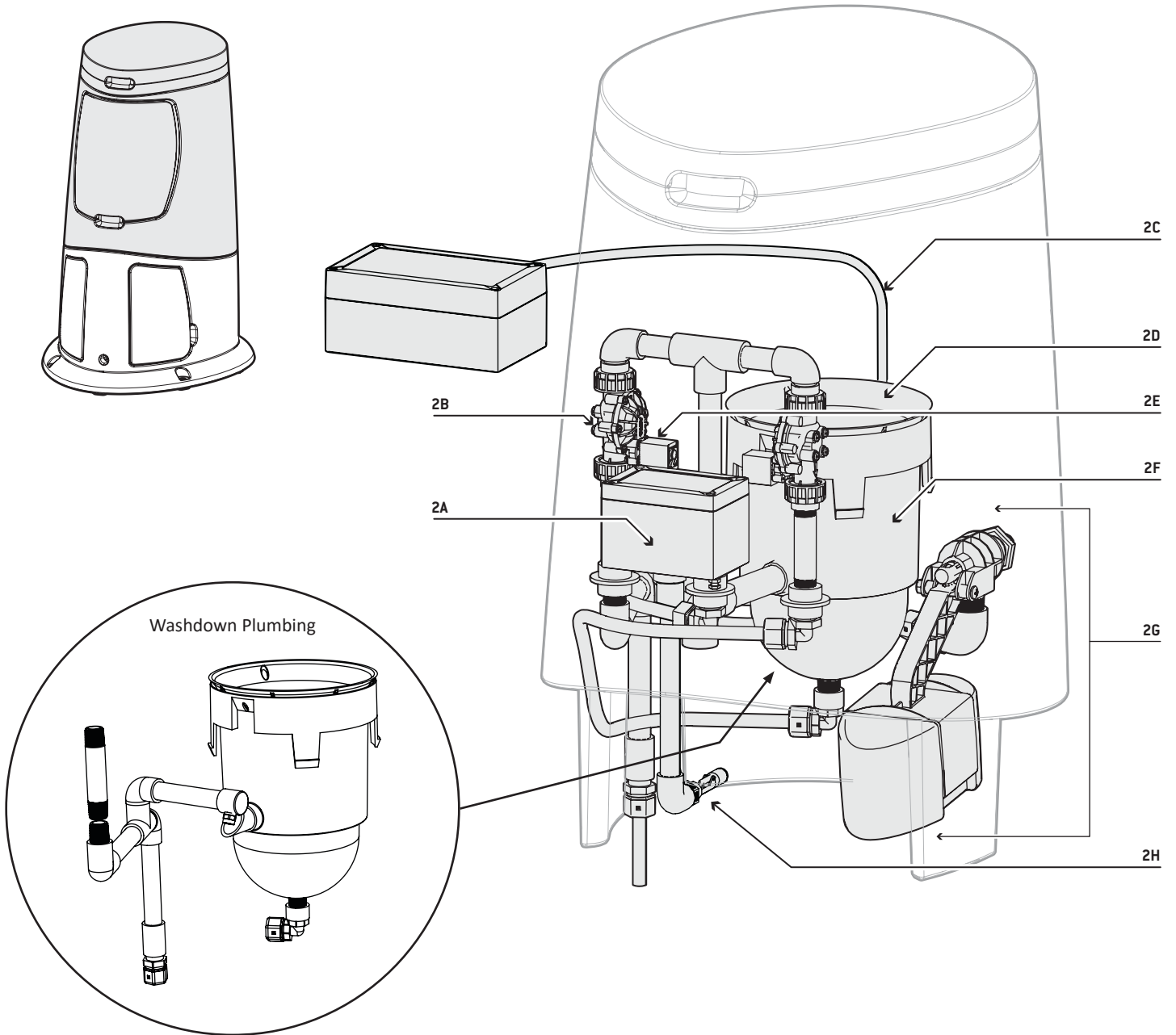

No	Description	Part Number
2: HOPPER INTERIOR COMPONENTS		
2A	Junction Box (comes with the Control Box)	N/A
2B	Solenoid Valve	79664
2C	Wiring Harness (comes with the Control Box)	N/A
2D	Grid Basket	73220
2E	DIN Cables	73261
2F	Chlorinator, HCE Nozzle	73085
2G	Emergency Shutoff Valve	73241
2H	High Level Switch	79840

Figure 14. Base Interior Components View

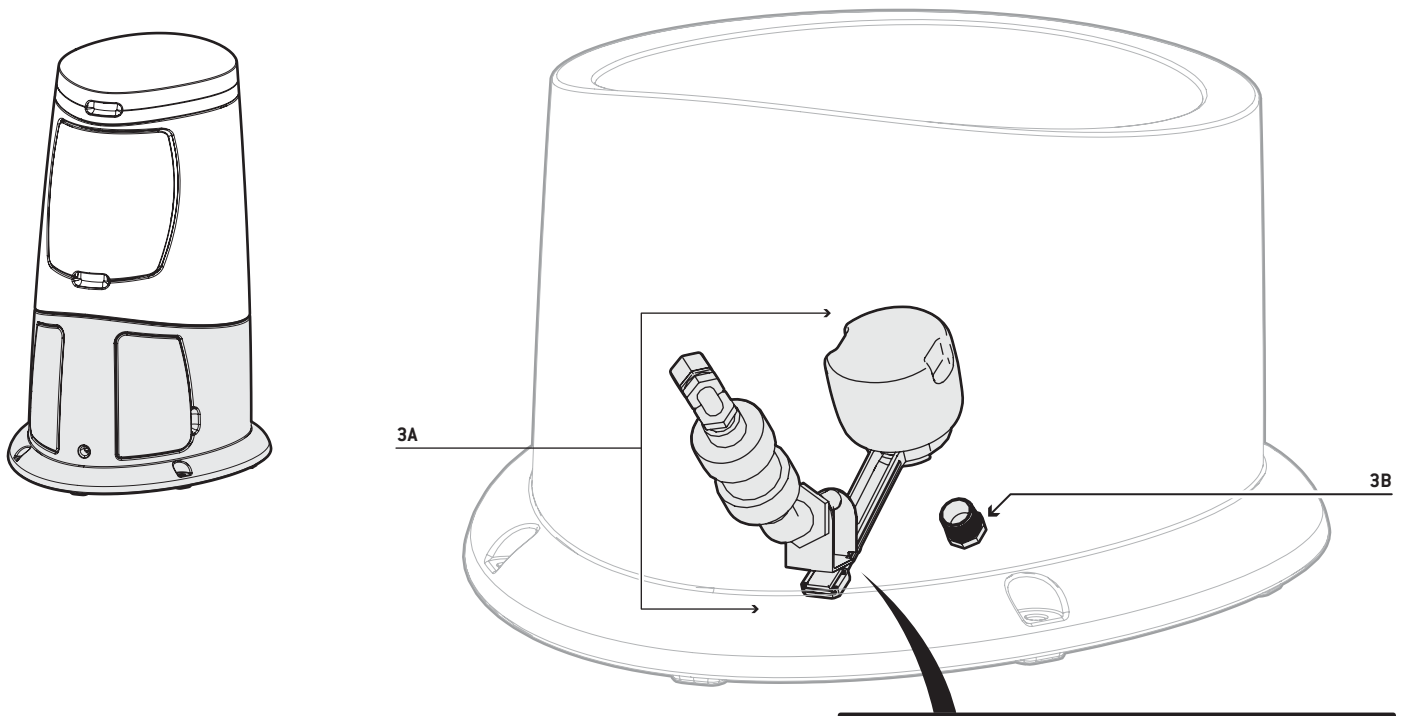

No	Description	Part Number
3: BASE INTERIOR COMPONENTS		
3A	Discharge Valve Assembly	79217
3B	3/4" NPT Plug PVC (replacement customer sourced)	N/A
3C	1/2" 90° Tubing Connector, W8ME8	71898
3D	PVC Check Valve	79218
3E	1/2" Threaded Nipple	71916
3F	1/2" 45° Threaded Elbow	79222
3G	Discharge Valve Nut	71583
3H	Discharge Valve Gasket	71576
3I	Discharge Valve Body	79806
3J	Discharge Valve Float	79810
3K	Discharge Valve Arm	79805

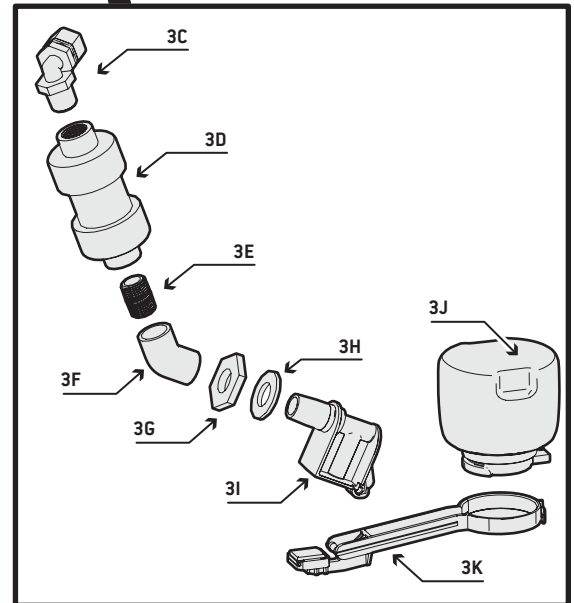

11 Limited Warranty

The Pulsar® Precision Feeder is warranted against any manufacturing defects in material or workmanship for a period of 12 months after installation or 18 months after shipping from Sigura, whichever is earlier. This warranty applies only to the original end-user.

Service

For warranty service, contact the authorized Pulsar® Precision Dealer in your area. Any defective part(s) covered by this warranty will be repaired or replaced, at Sigura's discretion. Replacement may be with either new or reconditioned parts.

Exclusions

This warranty does not cover damage or failure due to accidents, fire, flood, or other acts of God. Nor does it cover damage or failure due to abuse, misuse, abnormal or improper use, neglect, improper maintenance, alterations or modifications by anyone other than Sigura (unless specifically approved in writing by Sigura), repairs by anyone other than an authorized Dealer, or ordinary wear and tear.

Use of any briquettes or other chemicals other than the Pulsar® Plus Briquettes designed for use with this chlorinator shall void this warranty.

Any transportation to and from an authorized Pulsar® Precision Dealer is your responsibility.

Neither Sigura nor its Dealers are responsible or liable for indirect, special, or consequential damages arising out of or in connection with the use or performance of the product or other damages with respect to loss of property, loss of revenues or profit by the owner. EXCEPT AS PROVIDED ABOVE, Sigura MAKES NO WARRANTIES. ANY IMPLIED WARRANTY OF MERCHANTABILITY OR FITNESS FOR A PARTICULAR PURPOSE IS SPECIFICALLY EXCLUDED.

Note: No modifications may be made to the chlorinator without prior written approval from Sigura. Unauthorized modifications void any warranty. This Pulsar® Precision Feeder is subject to one or more patents owned by Sigura, and all rights in any modifications or improvements, including but not limited to any patents, copyrights, trademarks or trade secrets, belong exclusively to Sigura.

For information, contact Sigura at (800) 478-5727.

Pulsar® Systems

1400 Bluegrass Lakes Parkway

Alpharetta, GA 30004

www.pulsarsystems.net

1-800-4-PULSAR

Pulsar® and Pulsar® logos are trademarks of Innovative Water Care, LLC or its affiliates.

©2020 Innovative Water Care, LLC

